

Wpływ ciśnienia i kształtu elektrod świecy zapłonowej na przebieg napięcia i prądu w procesie jonizacji i po utworzeniu kanału plazmowego

Politechnika Wrocławska
Wydział Mechaniczny W10
Katedra Inżynierii Pojazdów K56

MSc. Adam Kamiński

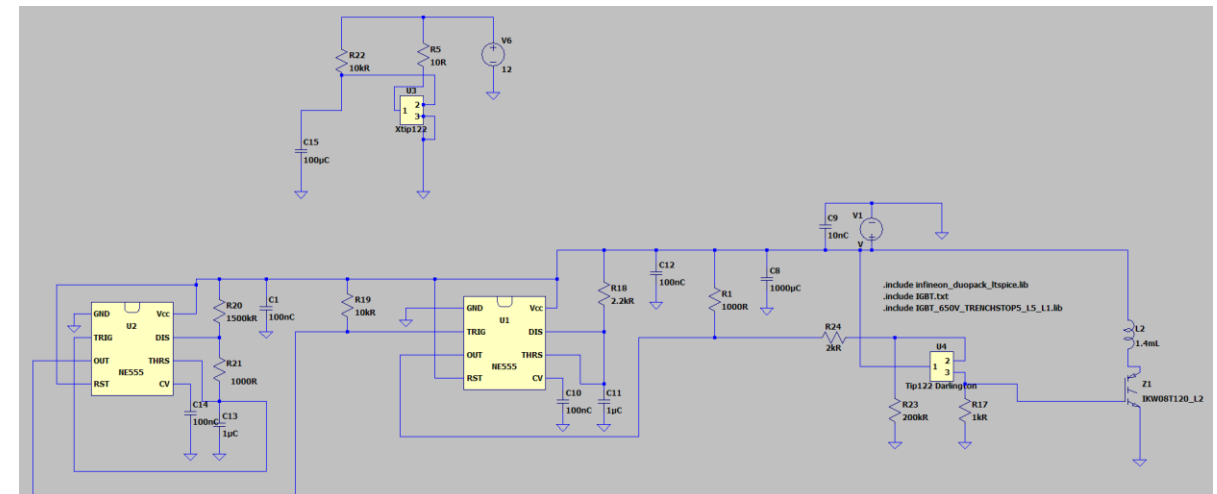



Brisk P10



Brisk EVO 360



Denso TT IX Iryd



Denso TT XU Platyna



Brisk Bor12LGS



Denso XU Miedziane

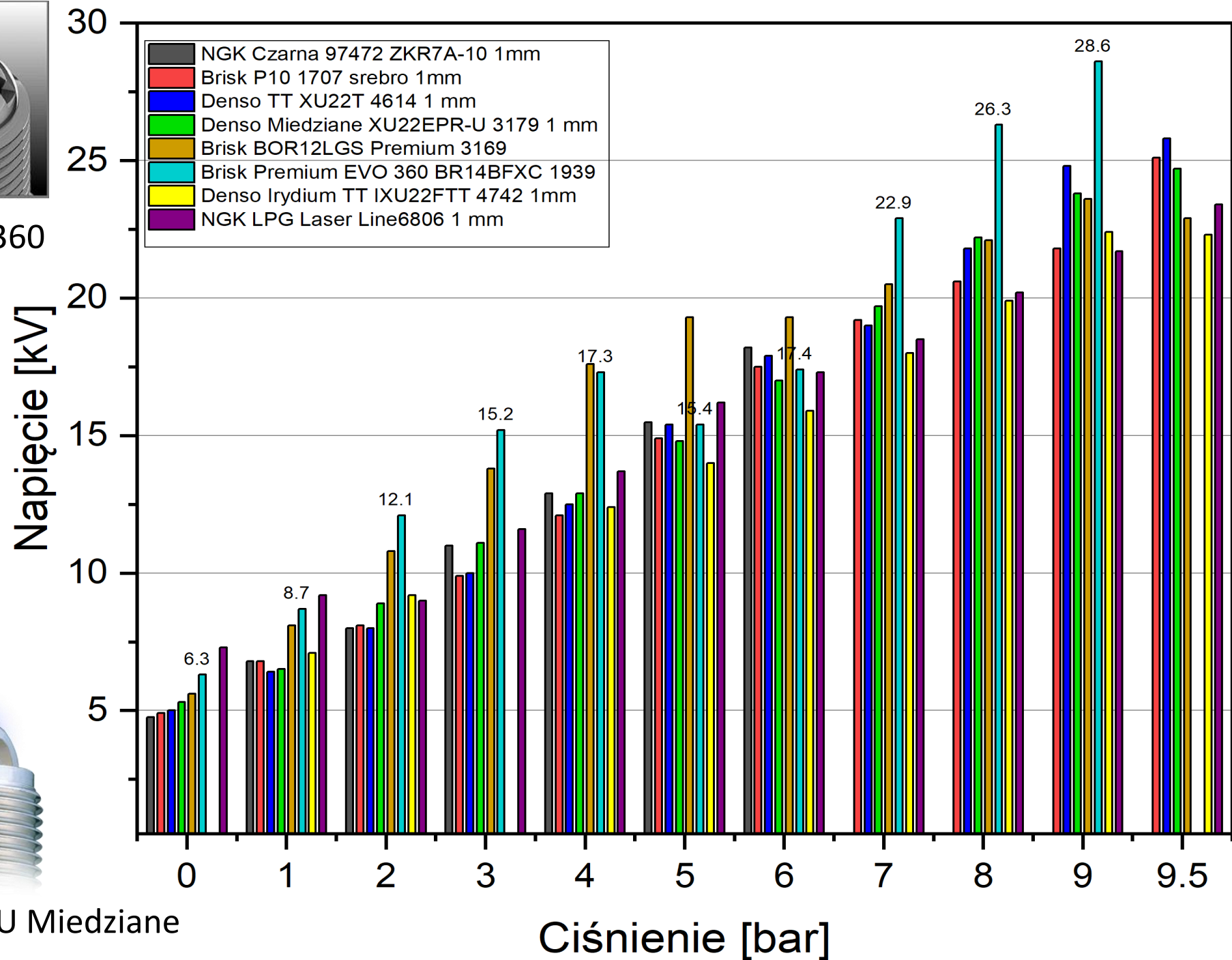

Stabilność zapłonu iskry

Brisk BOR12LGS Premium 3169 vs Denso TT XU22T 4614 1 mm – 9 bar

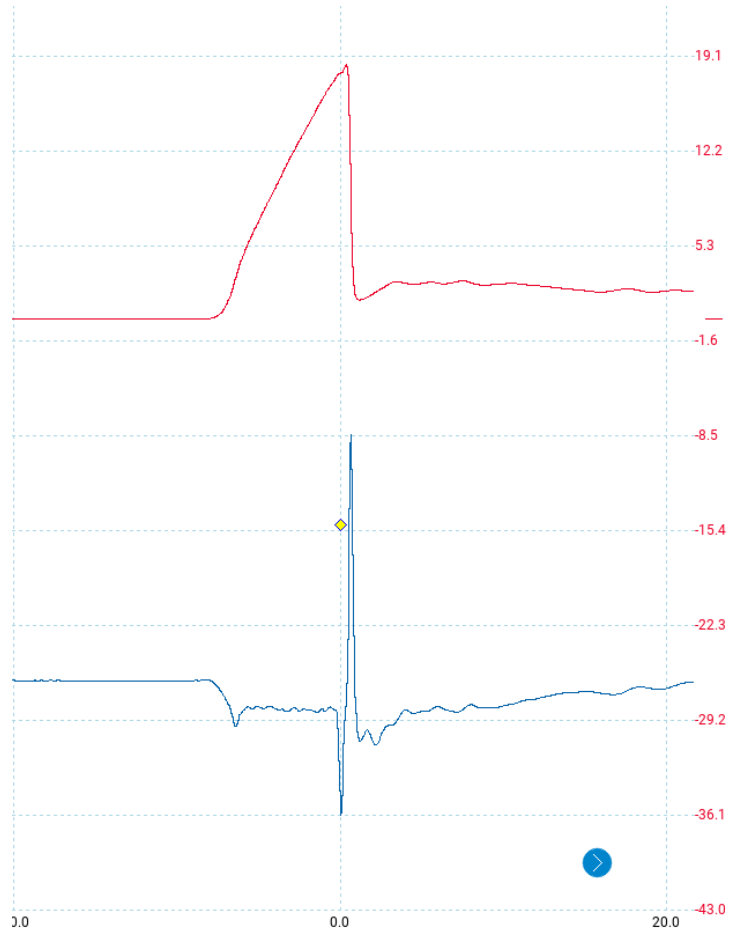

Brisk BOR12LGS Premium 3169

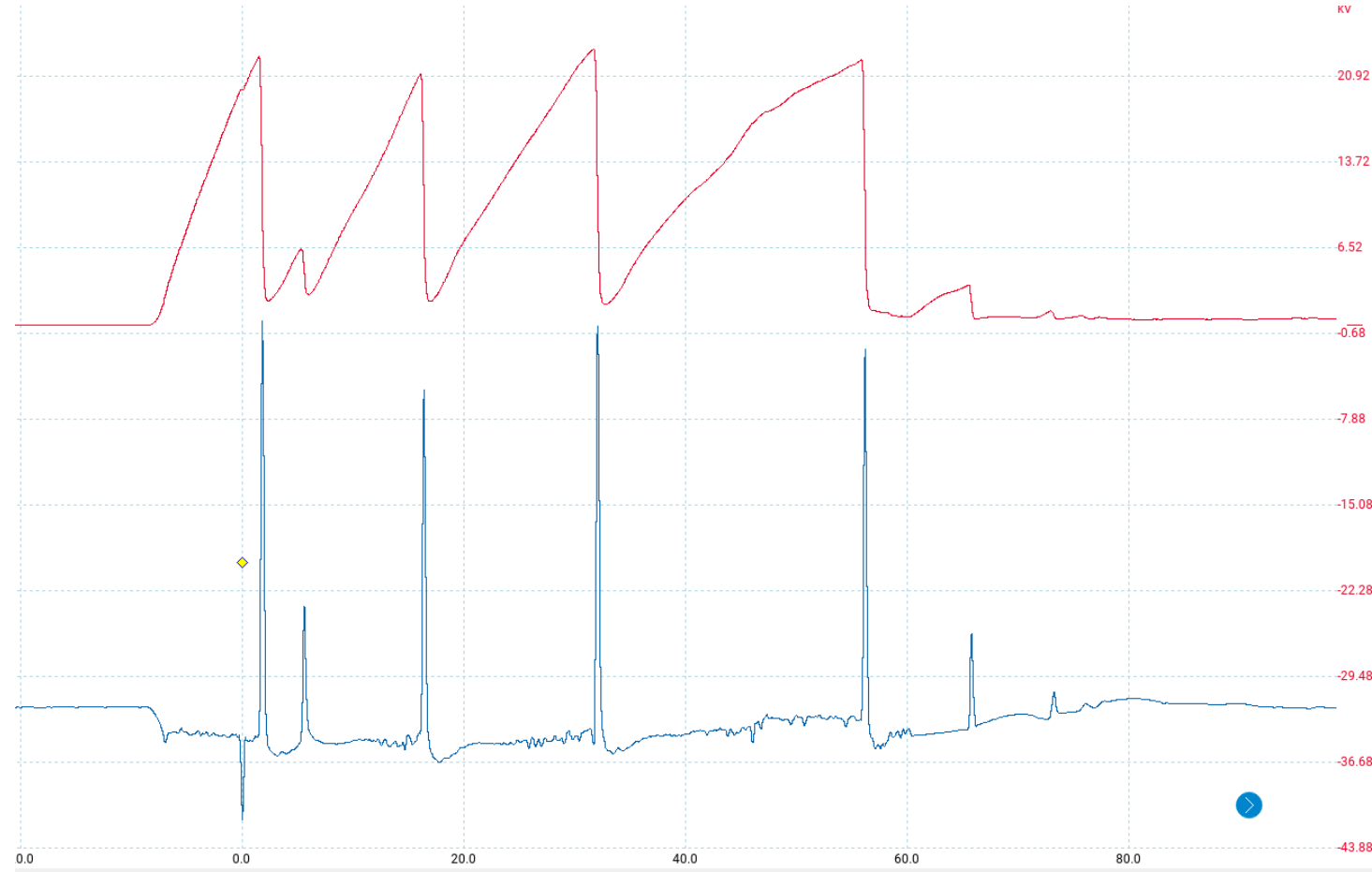

Denso TT XU22T 4614 1 mm – 9 bar